

**GENERAL NOTES:**

1. THE CONTRACTOR WILL NOT BE REQUIRED TO SUBMIT SHOP DRAWINGS OF LINER PLATE OR INSTALLATION ACCESSORY STRIPS IF THE DETAILS OF THE MATERIALS CONFORM TO THOSE SHOWN HEREON.
2. THE SHAPE OF THE LOCKING EXTENSIONS AS SHOWN IS NOT MANDATORY. THE SIZE AND SPACING AS SHOWN INDICATE THE MINIMUM REQUIREMENTS. THE CONTRACTOR MAY SUBMIT ALTERNATIVE DETAILS FOR THE ENGINEER'S APPROVAL.
3. LINER PLATE SHEETS SHALL BE OF PROPER LENGTH TO INSURE COMPLIANCE WITH THE REQUIREMENT HEREON THAT LOCKING EXTENSIONS EXTEND TO WITHIN 11/2" OF EACH END OF REINFORCED CONCRETE PIPE. VARIATION OF LENGTH DUE TO HANDLING OR TEMPERATURE CHANGE SHALL BE CONSIDERED AND LENGTH OF SHEET CORRECTED TO COMPLY WITH DIMENSIONS HEREON.
4. THE USE OF A 4" INTEGRAL STRIP WILL NOT BE PERMITTED ON BEVELED REINFORCED CONCRETE PIPE. PLASTIC LINER ON BEVELED PIPE SHALL BE JOINED WITH A TYPE P-1 JOINT.
5. THE CUTTING, NOTCHING, AND/OR REMOVAL OF LOCKING EXTENSIONS FROM LINER PLATE SHEETS SHALL BE DONE IN SUCH A MANNER SO AS NOT TO DAMAGE THE MAIN SHEET. ANY CUTS, GOUGES OR REMOVAL OF MATERIAL FROM THE MAIN SHEET WHICH CANNOT BE PROPERLY REPAIRED WILL BE CAUSE FOR REJECTION. WHERE LINER PLATE SHEETS ARE TO OVERLAP AND REMOVAL OF LOCKING EXTENSIONS IS REQUIRED, THE LOCKING EXTENSIONS SHALL BE REMOVED TO WITHIN 1/32" OF THE SURFACE OF THE MAIN SHEET.
6. ALL JOINTS SHALL BE SEALED ON THE BACK SIDE WITH 1" WIDE WELD STRIP OR 2" WIDE WATER RESISTANT SEALING TAPE CONFORMING TO ASTM D-2301, ASTM D-3006 AND ANSI N45.2.2 PRIOR TO PLACING THE CONCRETE.
7. PLASTIC LINER PLATE MAY BE OF ANY COLOR UNLESS OTHERWISE INDICATED IN THE CONTRACT DOCUMENTS.

**PIPE INSTALLATIONS**

BUREAU OF ENGINEERING		DEPARTMENT OF PUBLIC WORKS		CITY OF LOS ANGELES																																													
PLASTIC LINER PLATE DETAILS				STANDARD PLAN																																													
				<b>S - 121 - 1</b>																																													
SUBMITTED <i>9/22</i> 1982 <i>[Signature]</i> ENGINEER OF DESIGN <i>[Signature]</i> DEPUTY ENGINEER  APPROVED <i>9/22</i> 1982 <i>[Signature]</i> CITY ENGINEER				<table border="1" style="width: 100%; border-collapse: collapse;"> <thead> <tr> <th style="width: 5%;">NO.</th> <th style="width: 75%;">DESCRIPTION</th> <th style="width: 15%;">SUPERSEDES</th> <th style="width: 5%;">REFERENCES</th> </tr> </thead> <tbody> <tr> <td>1</td> <td>REARRANGED DETAILS; REVISED / ADDED NOTES; CHANGED DIMENSIONS;</td> <td>B-3963</td> <td></td> </tr> <tr> <td> </td> <td> </td> <td> </td> <td> </td> </tr> <tr> <td> </td> <td> </td> <td> </td> <td> </td> </tr> <tr> <td> </td> <td> </td> <td> </td> <td> </td> </tr> <tr> <td> </td> <td> </td> <td> </td> <td> </td> </tr> <tr> <td> </td> <td> </td> <td> </td> <td> </td> </tr> <tr> <td> </td> <td> </td> <td> </td> <td> </td> </tr> <tr> <td> </td> <td> </td> <td> </td> <td> </td> </tr> <tr> <td> </td> <td> </td> <td> </td> <td> </td> </tr> <tr> <td> </td> <td> </td> <td> </td> <td> </td> </tr> </tbody> </table>		NO.	DESCRIPTION	SUPERSEDES	REFERENCES	1	REARRANGED DETAILS; REVISED / ADDED NOTES; CHANGED DIMENSIONS;	B-3963																																					
NO.	DESCRIPTION	SUPERSEDES	REFERENCES																																														
1	REARRANGED DETAILS; REVISED / ADDED NOTES; CHANGED DIMENSIONS;	B-3963																																															
DESIGNED BY: JA		DRAWN BY: WPMD		CHECKED BY: RGS																																													
				VAULT INDEX NUMBER B-4105																																													
				SHEET 1 OF 5 SHEETS																																													

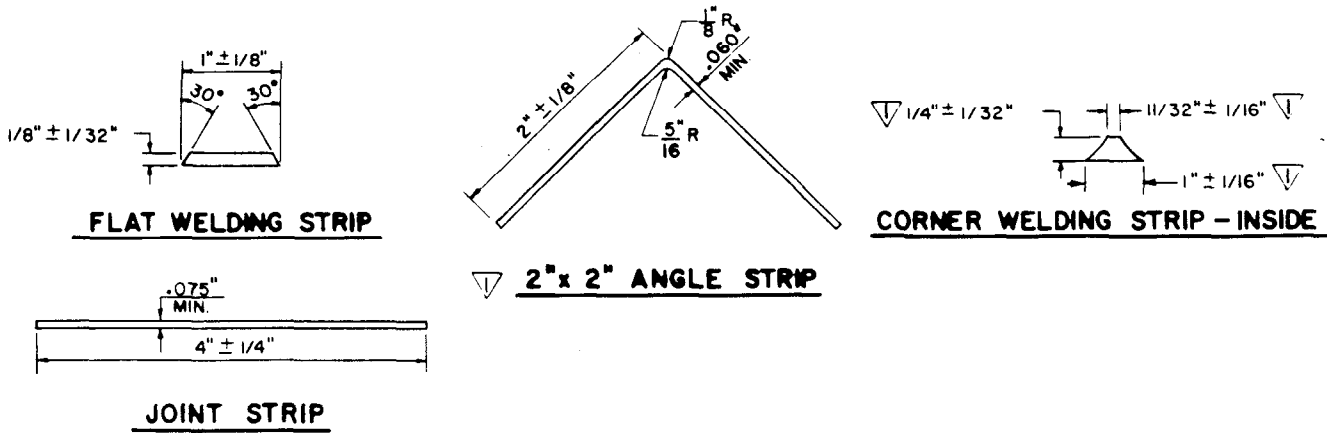

**STANDARD INSTALLATION  
ACCESSORY STRIPS**

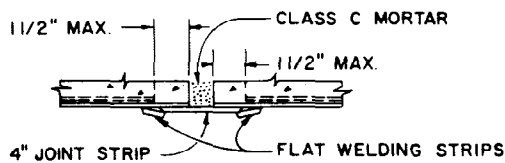

**TYPE P - 1**

- NOTES FOR TYPE P - 1:
- a. OPTIONAL FOR STRAIGHT PIPE.
  - b. SHALL BE USED FOR BEVELED PIPE.
  - c. BEVEL EDGES OF 4" JOINT STRIP PRIOR TO APPLICATION OF FLAT WELDING STRIP.

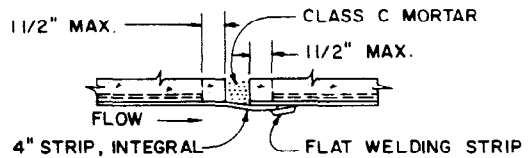

**TYPE P - 2**

- NOTES FOR TYPE P - 2:
- a. MAY BE USED FOR STRAIGHT PIPE ONLY.

**JOINTS FOR PIPE**

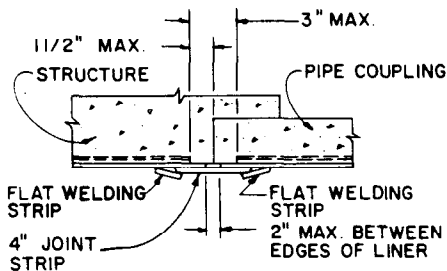

**TYPE C - 1**

- NOTES FOR TYPE C - 1:
- a. SHALL BE USED AT PIPE COUPLINGS.
  - b. BEVEL EDGES OF 4" JOINT STRIP PRIOR TO APPLICATION OF FLAT WELDING STRIPS.

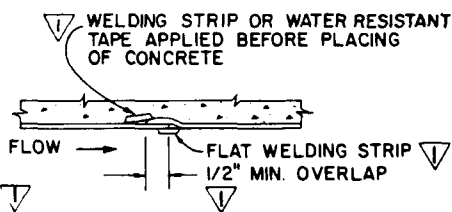

**TYPE C - 2**

- NOTES FOR TYPES C-2 AND C-3:

- a. MAY BE USED FOR ALL PLASTIC LINER JOINTS EXCEPT THOSE AT TRANSVERSE CONTRACTION JOINTS.
- b. LINER PLATE RETURN DETAIL D-6 SHALL BE USED AT TRANSVERSE CONTRACTION JOINTS.
- c. AN 8" LONG FLAT WELDING STRIP, CENTERED OVER THE VERTICAL FLAT WELDING STRIP, SHALL BE INSTALLED ON ALL VERTICAL LINER PLATE JOINTS THAT EXTEND TO THE LOWER TERMINAL EDGE OF THE LINER PLATE.

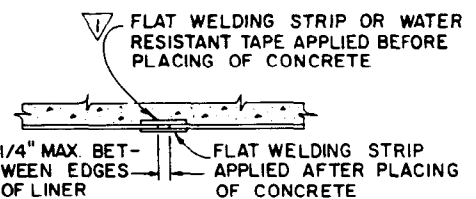

**TYPE C - 3**

**JOINTS FOR CAST - IN - PLACE STRUCTURES**

**FIELD JOINTS**

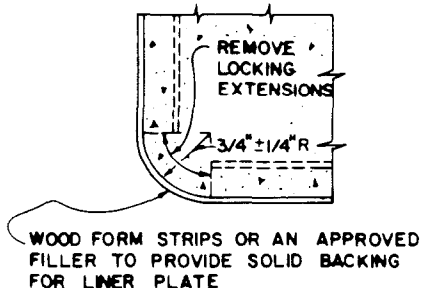

**OUTSIDE CORNER**  
D-1

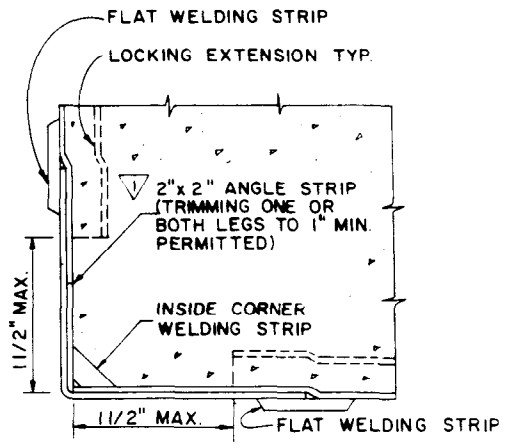

**OPTIONAL OUTSIDE CORNER**  
D-2

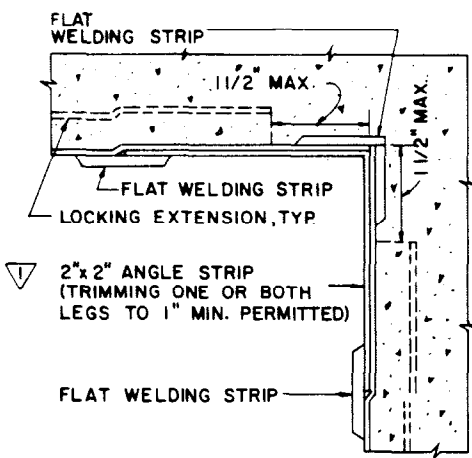

**OPTIONAL INSIDE CORNER**  
D-3

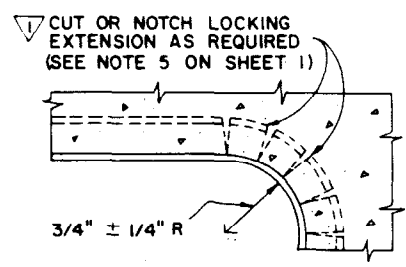

**INSIDE CORNER**  
D-4

**CORNER DETAILS**

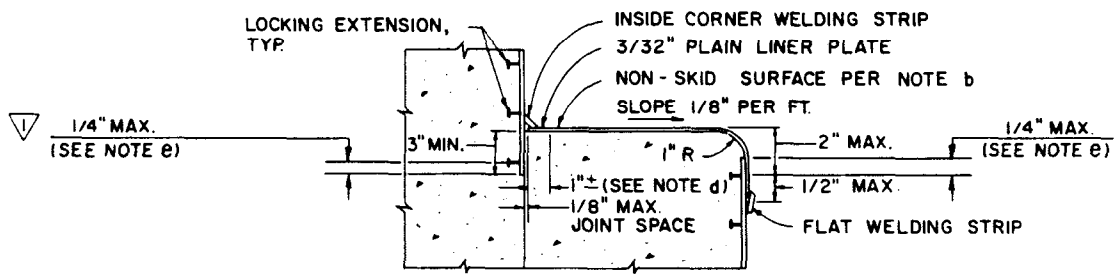

**NOTES FOR SHELF LINER:**

- a. SHELF SHALL BE STEEL TROWEL FINISHED.
- b. NON-SKID SURFACE FOR THE PLASTIC LINER PLATE SHALL BE PREPARED IN ACCORDANCE WITH THE APPLICABLE SECTION OF THE STANDARD SPECIFICATIONS FOR PUBLIC WORKS CONSTRUCTION. SUCH PREPARATION SHALL BE PERFORMED ABOVE GROUND.
- c. NO ADHESIVE SHALL BE USED FOR THE APPLICATION OF THE PLASTIC LINER PLATE TO SHELF.
- d. NON-SKID SURFACE SHALL BEGIN 1"± FROM EDGE OF THE PLASTIC LINER PLATE AS SHOWN.
- e. TERMINATION OF LINER BEYOND LOCKING EXTENSION SHALL BE 1/4" MAXIMUM.

**SHELF LINER**  
D-5

MATERIALS NOT PLASTIC LINED

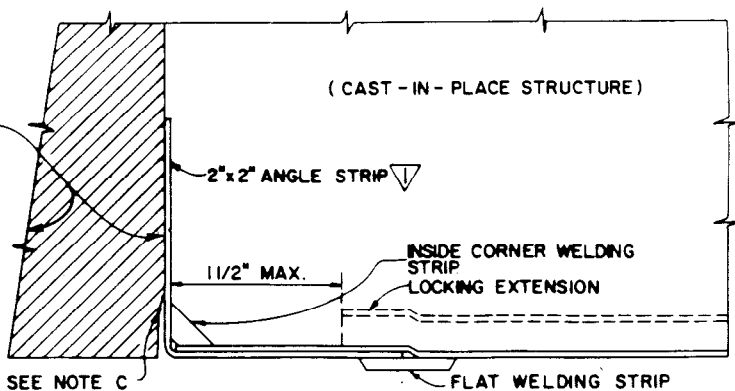

**LINER PLATE RETURN**

D-6

NOTES FOR LINER PLATE RETURN:

- a. SHALL BE USED AT STRAIGHT LINE RETURNS EXCEPT AS OTHERWISE DETAILED HEREON AND ON THE PROJECT PLANS.
- b. ANGLE STRIP SHALL BE SEALED TO ADJACENT MATERIAL WITH AN APPROVED EPOXY.
- c. AN APPROVED EPOXY SHALL BE USED FOR CAULKING.

FLAT WELDING STRIP, TYP

REMOVE INTERFERING LOCKING EXTENSION

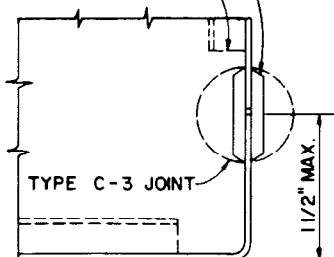

**SECTION C - C**

NOTE:

SEE DETAIL D-2 FOR ALT.

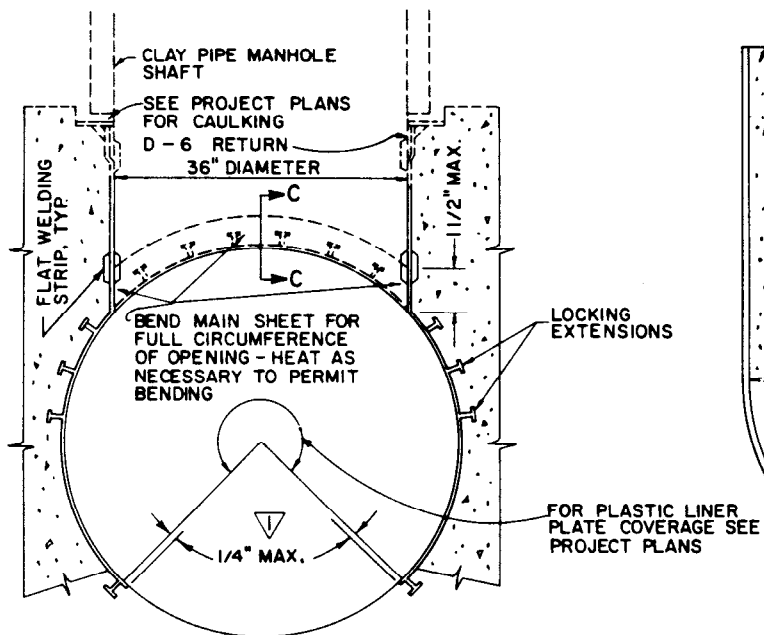

**CORNER - MANHOLE SHAFT**

D-7

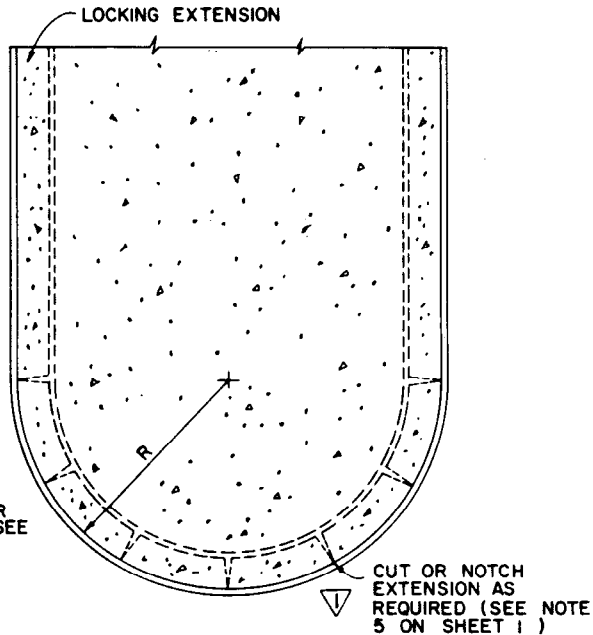

**LINER PLATE INSTALLATION AT CURVED SURFACES**

D-8

NOTE FOR DETAIL D-8:

- a. A WEEPER PER DETAIL D-11 SHALL BE INSTALLED AT THE LOWEST POINT ON THE CURVED SURFACE WHEN THE CURVED SURFACE (NOSE) IS LOCATED BETWEEN DIVERGING FLOWS.

**MISCELLANEOUS DETAILS**

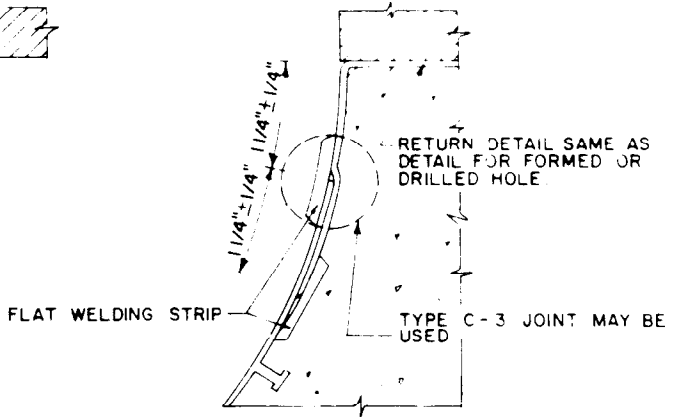
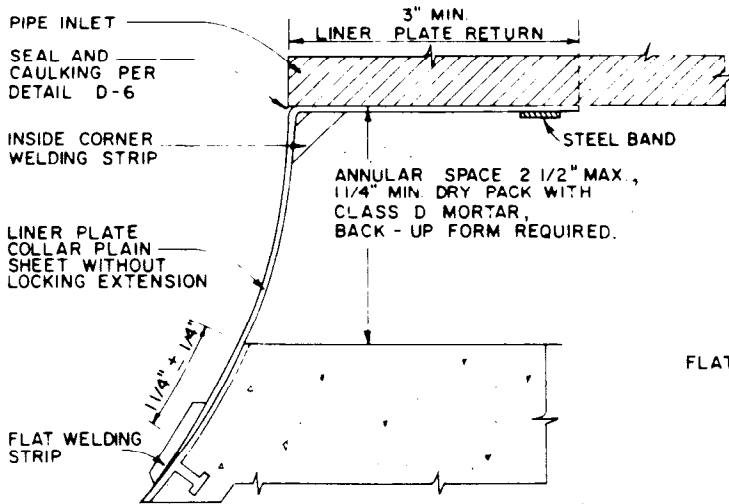

**INSTALLED IN FORMED OR DRILLED HOLE**

**CAST INTEGRALLY WITH STRUCTURE**

**NOTES FOR INLET DETAILS:**

- a. SHALL BE USED FOR ALL PIPE INLETS UNLESS OTHERWISE SHOWN ON THE PROJECT PLANS.
- b. FOR PIPE INLET INSTALLATION AND STRUCTURAL REQUIREMENTS SEE THE PROJECT PLANS.
- c. LINER PLATE RETURN SHALL BE A SINGLE SHEET SPLICED AT THE SOFFIT OF THE INLET PIPE USING ONE OR TWO WELDING STRIPS.
- d. LINER PLATE COLLAR SHALL BE FABRICATED FROM PLAIN LINER PLATE SHEET IN ONE PIECE FOR PIPE INLETS 12" OR LESS IN DIAMETER.

**INLET DETAILS**

D-9

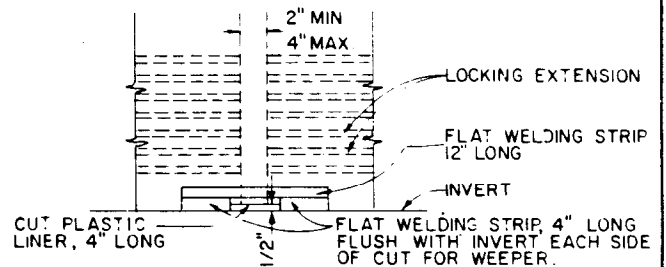
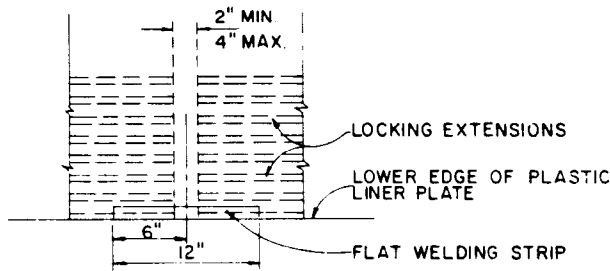

**INTERMEDIATE PIPE WEEPER REINFORCEMENT**

D-10

**STRUCTURE WEEPER OUTLET**

D-11

**NOTES FOR DETAIL D-11:**

- a. PROVIDE THIS OUTLET FOR EACH WEEPER AT 8 FT C-C, MAXIMUM, WITH A MINIMUM OF ONE FOR EACH SEPARATE WALL SURFACE. DETAIL SHALL ALSO APPLY WHERE LINER PLATE IS EXTENDED BELOW OTHER INTERSECTING CONCRETE SURFACES.
- b. WELDING STRIPS SHALL BE CENTERED OVER WEEPER.

**WEEPER DETAILS**

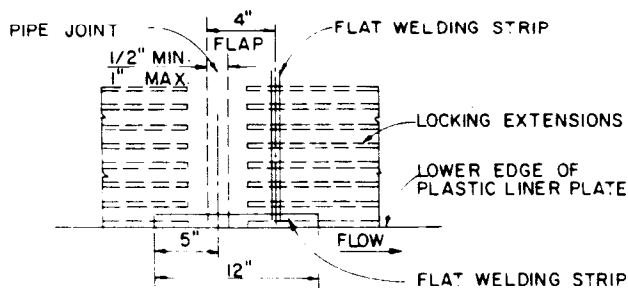

**NOTES FOR DETAIL D-12:**

- a. DETAIL AS SHOWN IS FOR TYPE P-2 JOINT. FOR TYPE P-1 THE 12" LONG FLAT WELDING STRIP SHALL BE CENTERED OVER THE PIPE JOINT.
- b. THE LENGTH FOR THE FLAT WELDING STRIP AT THE LOWER EDGE OF THE PLASTIC LINER PLATE SHALL BE INCREASED ACCORDINGLY AT PULLED JOINTS.
- c. THE MAXIMUM OFFSET AT THE LOWER TERMINUS OF THE LINER PLATE IS 1" FOR OFFSETS EXCEEDING 1". THE METHOD OF REPAIR SHALL BE AS DIRECTED BY THE ENGINEER.

**PIPE JOINT REINFORCEMENT AT LOWER EDGE OF PLASTIC LINER PLATE**

D-12