

NOTE:
JOINTS, NOT SHOWN,
SHALL BE AS PER
TYPICAL JOINT PLAN
HEREON.

TYPICAL INTERSECTION GUTTER PLAN

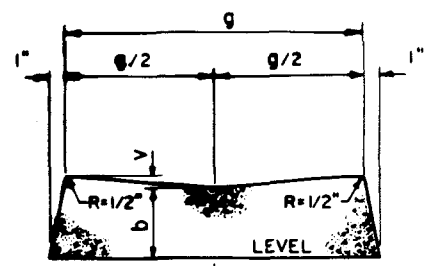

CROSS GUTTER OR LONGITUDINAL GUTTER

CROSS GUTTER		LONGITUDINAL GUTTER	
g	v	g	v
		2'	3/4"
4'	3/8"	4'	1-1/2"
4'+TO 6'	5/8"	4'+TO 6'	2"

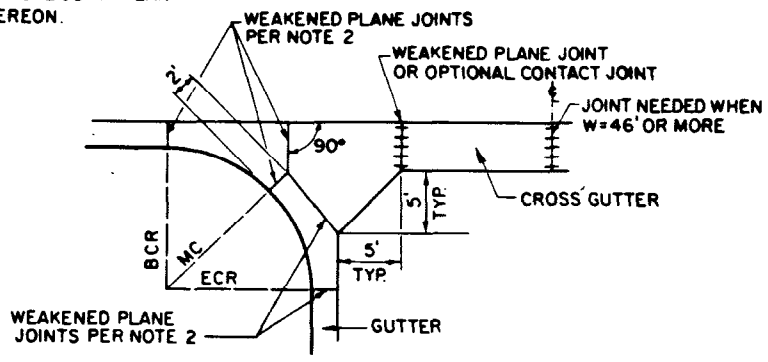

TYPICAL JOINT PLAN

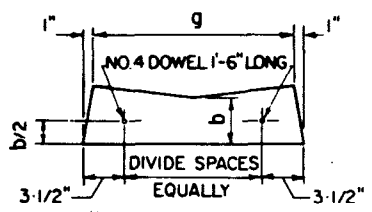

g	NO. OF DOWELS
2'	2
4'	4
6'	6

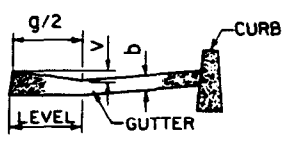

SECTION A-A

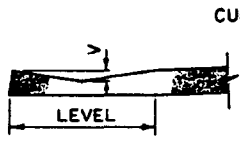

SECTION B-B

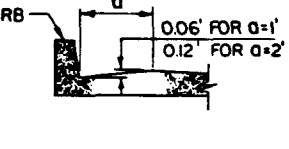

SECTION C-C

DOWELS FOR GUTTER CONTACT JOINTS

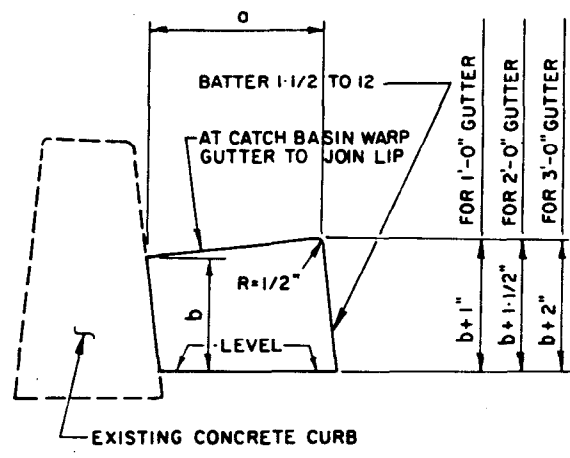

CONCRETE GUTTER

GUTTERS

NOTES

- ▽ 1. CURBS AND GUTTERS SHALL BE CONSTRUCTED OF PCC CONFORMING TO SUBSECTION 201-1 AND 303-5.
- ▽ 2. WEAKENED-PLANE JOINTS IN CURB AND GUTTER SHALL CONFORM TO STANDARD SPECIFICATIONS FOR PUBLIC WORKS CONSTRUCTION SUBSECTION 303-5.4.3 (C) OR SHALL BE 1-1/2 INCH DEEP SAWCUTS MADE WITHIN 10 TO 24 HOURS AFTER CONCRETE IS PLACED AND SHALL BE PLACED AT LOCATIONS SHOWN ON THE TYPICAL JOINT PLAN HEREON AND AT REGULAR INTERVALS NOT EXCEEDING 20 FEET BETWEEN RETURNS. THEY SHALL ALSO BE LOCATED AT THE E.C. OF ALLEY RETURNS WHERE WALK IS FULL WIDTH. WHERE CROSS GUTTER TRANSITION EXTENDS BEYOND THE CURB RETURN, THE JOINTS SHALL NORMALLY BE PLACED AT THE ENDS OF THE TRANSITION. HOWEVER, JOINTS SHALL ALSO BE PLACED AT THE ENDS OF THE CURB RETURN WHEN THE CROSS GUTTER TRANSITION EXTENDS MORE THAN 5 FEET BEYOND THE RETURN. WHERE GUTTER IS ADJACENT TO CONCRETE PAVEMENT, THE JOINT SHALL BE ALIGNED WITH THE PAVEMENT JOINTS WHERE PRACTICAL.
- ▽ 3. A CONTACT JOINT SHALL BE PLACED IN LONGITUDINAL ALLEY GUTTER WHERE IT JOINS CONCRETE ALLEY INTERSECTION.
- ▽ 4. CURBS CONSTRUCTED ADJACENT TO EXISTING CURBS HAVING A BATTER OTHER THAN SPECIFIED FOR THE NEW CURBS SHALL BE CONSTRUCTED WITH A TRANSITION SECTION BETWEEN THE CURBS HAVING DIFFERENT BATTERS. THE MINIMUM TRANSITION LENGTH SHALL BE:

<u>TYPE OF CURB</u>	<u>MINIMUM TRANSITION LENGTH</u>
BARRIER CURB TO BARRIER CURB	5'
MOUNTABLE CURB TO MOUNTABLE CURB	10'
BARRIER CURB TO MOUNTABLE CURB	20'

- ▽ 5. THE DOWELS IN THE DOWELED CURB MAY BE DELETED AND THE CURB BONDED TO THE SURFACE BY A BONDING AGENT APPROVED BY THE ENGINEER.
- ▽ 6. MOUNTABLE CURBS SHALL NOT BE USED ADJACENT TO PEDESTRIAN WALKWAYS.
- ▽ 7. DIMENSIONS: (UNLESS OTHERWISE SPECIFIED)
- a=2'-0"
b=0'-6"
c=10'-0"